

**AG-MI-2015-02-C-EN – Change of Measurement Method
from Cylinder Head Temperature to
Coolant Temperature**

Category C

EFFECTIVE DATE

29.04.2015

SUPERSEDES/REPLACES

N/A (initial issue)

APPLICABILITY

All gyroplanes with Rotax 912 ULS and Rotax 914 UL engines equipped with new cylinder heads. For further information see Rotax Service Bulletins and Temporary Revisions in latest revision listed under 'References'.

COMPLIANCE

To be performed within the next maintenance event

BACKGROUND

Design change of the Rotax 912 ULS and Rotax 914 UL cylinder heads (introduced 01.03.2013) regarding the measurement procedure for cylinder head temperature (CHT) respectively coolant temperature (CT)

RISK OF NEGLECT

Failure to comply with this instruction/information will result in

- possible damage to the aircraft
- loss of related warranty

SCOPE OF WORK

For engines equipped with new cylinder heads (see figures 1 and 2) change instrument marking of the cylinder head temperature indicator (CHT) to coolant temperature (CT). A replacement instrument will be purchasable later.

AFFECTED AREAS

Pilot Operating Handbook chapter 2.6 "Power Plant Limitations and Instrument Markings"

SPECIAL TOOLS & CONSUMABLE MATERIALS

PARTS

PC	PIT	Description	Remark
L0	M.EL01.74	CHT to watertemp	MTOsport
L0	C.EL01.45	CHT to watertemp	Calidus
L0	V.EL202.24	CHT to watertemp	Cavalon

LABOR AND REQUIREMENTS

To inspect	0.1 h
To accomplish	0.1 h

Task may only be performed by an organization or individual trained and entitled to do 'Line Maintenance' or by the aircraft holder.

Contact & Info:
airworthiness@auto-gyro.com
www.auto-gyro.com

AutoGyro GmbH
Dornierstr. 14
31137 Hildesheim

SUPPORT POLICY

Modification set "CHT to watertemp" f.o.c.

REFERENCES

Rotax SB-912-066UL in latest revision

Rotax SB-914-047UL in latest revision

Rotax TR-IM 912-001 in latest revision

Rotax TR-IM 914-001 in latest revision

Manufacturer Maintenance Manual (MMM) in latest revision

DOCUMENTATION

The accomplishment of this Manufacturer Information, or the decision of its rejection, must be properly documented, if such procedure is required by the relevant authority.

Warnings Caution and Notes

This instruction uses **WARNINGS**, **CAUTIONs** and **NOTEs** in bold italic letters to indicate especially critical and important instructions. The call-outs appear at the top of the Maintenance Job Card if of general nature or applicable for the complete task, or will directly precede the individual Work Step.

The meaning of each call-out is defined below:

WARNING: A warning means that the neglect of the appropriate procedure or condition could result in personal injury or fatal accidents.

CAUTION: A caution means that the neglect of the appropriate procedure or condition could result in damage to or destruction of equipment.

NOTE: A note stresses the attention for a special circumstance, which is essential to emphasize.

Category Codes

- A** Safety critical - failure to comply may result in a significant reduction of flight safety, injury or death
- B** Important - failure to comply may result in reduced safety margin, injury and/or equipment damage
- C** Beneficial - improves operating behaviour, reliability and/or maintainability

Contact & Info:
airworthiness@auto-gyro.com
www.auto-gyro.com

AutoGyro GmbH
Dornierstr. 14
31137 Hildesheim

COMPLIANCE PROCEDURE

GENERAL, REFERENCES AND REQUIREMENTS

Task may only be performed by an organization trained and entitled to do 'Line Maintenance' or by the aircraft holder.

Secure gyroplane against unauthorized or unintended operation!

Gyroplane must be placed on level ground and restrained (blocks, chocks)

Rotax SB-912-066UL in latest revision

Rotax SB-914-047UL in latest revision

Rotax TR-IM 912-001 in latest revision

Rotax TR-IM 914-001 in latest revision

Manufacturer Maintenance Manual (MMM) in latest revision

SPECIAL TOOLS, CONSUMABLE MATERIALS AND PARTS

PRECAUTIONS AND SAFETY MEASURES

PROCEDURES

- 1 If necessary: Remove engine cowlings according to MMM 52-00-00 4-1
- 2 Check configuration state regarding cylinder head design (see figures 1 and 2)
If new cylinder head design is detected:
- 3 Clean CHT instrument glass with glass cleaner
- 4 Change cockpit instrument for cylinder head temperature (CHT) to coolant temperature (CT) using the modification set (see Parts List). Therefore in accordance with Fig. 3:
 - Stick the red radial on the instrument glass at 120°C
 - Stick coolant temperature pictogram on the instrument glass above "CHT"

PARTS LIST

Fig.	Pos.	Description	PC PIT	Remark
3		CHT to watertemp	L0 M.EL01.74	MTOsport
3		CHT to watertemp	L0 C.EL01.45	Calidus
3		CHT to watertemp	L0 V.EL202.24	Cavalon

ILLUSTRATIONS

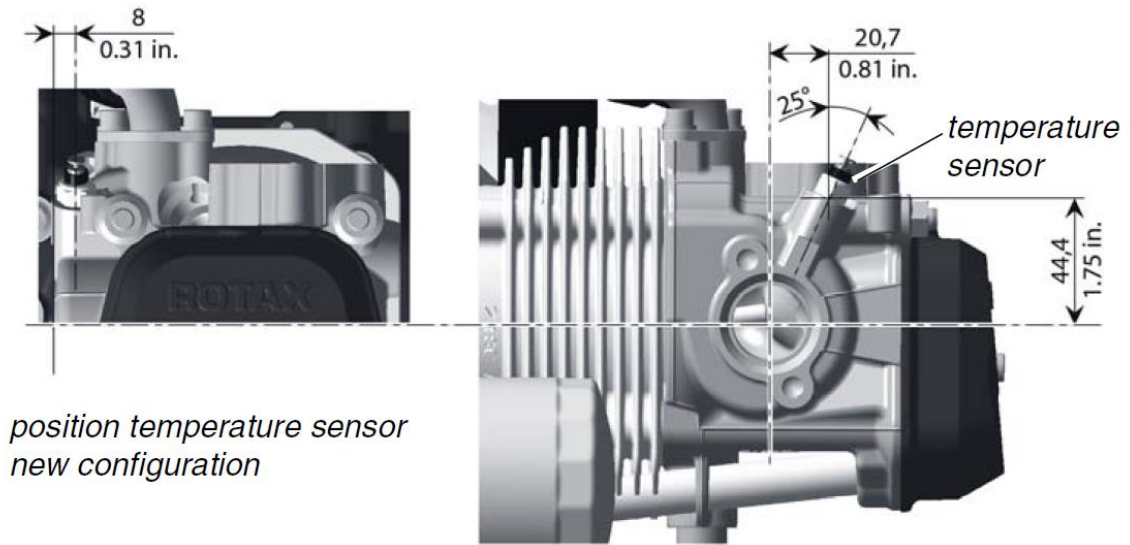

Fig. 1 – New generation cylinder head (measurement of CT)

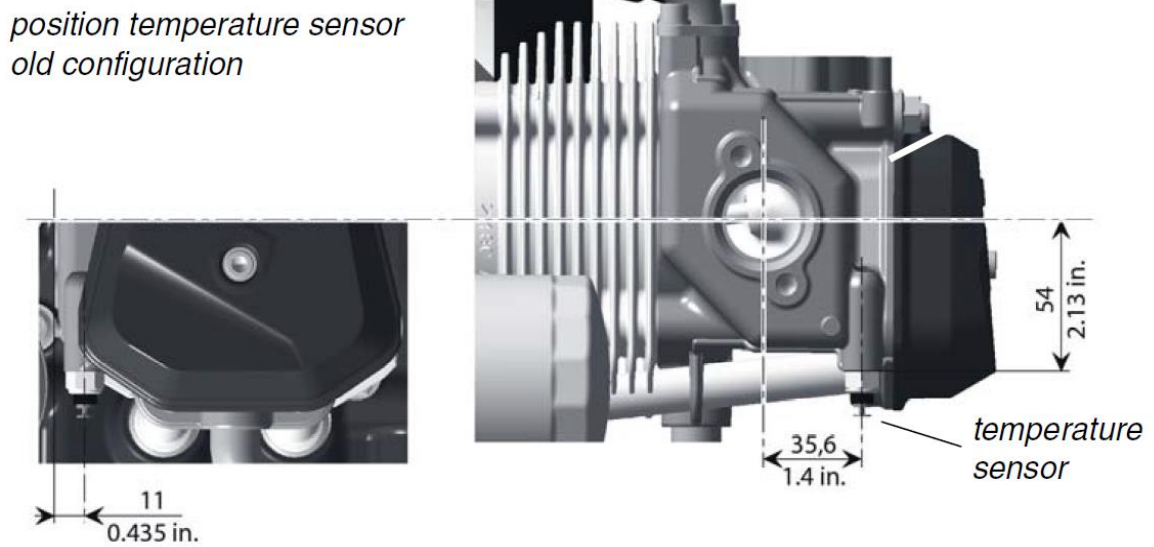

Fig. 2 – Old cylinder head (measurement of CHT)



Fig. 3 – Modification of the CHT indicator to CT indicator