

# RotorSport UK Ltd Service Bulletin (Permit)

|  |  |  |
|--|--|--|
| <b>Title: Improved Cavalon 915is oil cooling system</b>  |  | <b>Release date 10.10.2020</b>   |
| <b>SB-137 Iss1</b>   | <b>Related documents</b><br>Modification:<br>CCAR No.: None  | <b>Compliance Category:</b><br><br><b>OPTIONAL</b> <del>or</del><br><b>RECOMMENDED</b> <del>or</del><br><b>MANDATORY</b> |
| <b>Applicability</b>   |  |  |
| <b>Aircraft type &amp; model:</b><br>Cavalon 915IS   | <b>Aircraft serial Nos. affected:</b><br>RSUK/CVLN/032 and 033<br>RSUK-V00425, 426, 428, 433, 447,<br>449, 450, 453, 454, 455, 456, 458,<br>468. |  |
| The maintenance manual to be referenced is this stated or subsequent issue.  |  | None   |
| <p>This form is the response from RotorSport UK Ltd either against a problem found in the product in service requiring a containment or rectification action, or as service information for aircraft modification incorporation. For help, contact RotorSport on 44(0)1588 505060, or email <a href="mailto:compliance@rotorsport.org">compliance@rotorsport.org</a>.</p> <p>The technical content of this document is approved under the authority of the UK CAA Design Organisation<br/>Approval Ref: <b>DAI/9917/06</b></p> |  |  |

## Documentation (Service Bulletin Completion action)

- a) Entries within the aircraft logbooks, eg CAA BCAR A3-7 Authorised Person to certify that the work is completed by writing '*SB-137 Oil hose and thermostat replaced.*' in the aircraft logbook white pages, and record the action in the pink pages entitled 'Aircraft Modifications'. Both entries must be signed by the CAA Authorised Person together with their CAA Authorisation number.
- b) Completion of the SB worksheet attached. This must contain a PMR statement, and a final check item that no tools or equipment have been left within the aircraft.
- c) Complete the Type Approval change application document. (This is required where the SB will affect the type approval limitations, eg airspeed change or MTOW change and enables the owner to request the permit change required)
- d) Any other Permit Maintenance Release to Service form requirements.

| <b>Document approval signatures</b> |  |   |                              |
|-------------------------------------|--|---|------------------------------|
| <b>Engineering Manager</b>          | <b>CVE (as required)</b><br><br><b>Not required, change already approved</b> | <b>Chief Test Pilot (if flight performance or safety effect)</b><br><br><b>Not required</b> | <b>Head of Airworthiness</b> |

# RotorSport UK Ltd Service Bulletin (Permit)

## **Reason and overview of the Service Bulletin (cause of problem if known)**

AutoGyro has received feedback from the market that in some circumstances in flight, particularly at altitude, the Rotax 915iS engine oil pressure can fall to its minimum operating pressure of 2 bar.

AutoGyro have developed an improved thermostat and oil cooler circuit that replaces the original assembly, improving oil flow and system pressure.

This service bulletin provides instructions on how to replace the oil thermostat and hose assembly.

## **Manpower estimates**

Estimated man-hours to complete the task as a stand-alone item is; approx. 2hrs

## **Compliance: *Optional***

## **Tooling required**

See AutoGyro SB

## **Weight and Balance Effects**

No effect

## **Manuals affected**

Not affected.

## **Previous Modifications that affect the SB**

None

## **Accomplishment instructions (Action required to implement this bulletin):**

1. Follow the requirements of AutoGyro AG-SB-2020-02-B-EN.

## **Material information (Parts required to be made to implement this service bulletin):**

No parts made during embodiment

## **List of components (with purchasable part nos)**

None

## **Interchangeability**

Not affected

## **Parts disposition**

- a) Disposal requirements – None
- b) Environmental hazards of parts containing hazardous materials - None
- c) Scrap requirements (e.g. mutilate scrapped items beyond use) – None.

|  |  |  |
|--|--|--|
| <b>Title: Cavalon Oil Thermostat Assembly Upgrade</b>  |  | <b>Compliance Category:</b><br><br><b>A – MANDATORY</b><br><b>B – RECOMMENDED</b><br><b>C – OPTIONAL</b> |
| <b>AG-SB-2020-02-B-EN</b>  |  |  |
| <b>Applicability</b>   |  |  |
| <b>Aircraft type &amp; model:</b><br><br>AutoGyro Cavalon  | <b>Affected Serial number(s):</b><br><br>All Cavalon fitted with the Rotax 915iS engine up to V00473 but excluding V00398, V00443 & V00450 |  |
| The maintenance manual to be referenced is this stated or subsequent issue.  |  | As per AutoGyro website  |
| <p>This form is the response from AutoGyro GmbH either against a problem found in the product in service requiring a containment or rectification action, or as service information for aircraft modification incorporation.<br/>For help, contact AutoGyro on +49(0)5121 88056-00, or email <a href="mailto:airworthiness@auto-gyro.com">airworthiness@auto-gyro.com</a>.</p> |  |  |

**Documentation (Service Bulletin Completion action)**

The accomplishment of this Service Bulletin, or the decision of its rejection, must be properly documented, if such procedure is required by the relevant authority

**Category Codes**

A – Mandatory – failure to comply result in a significant reduction of flight safety, injury or death  
 B – Recommended – failure to comply may result in reduced safety margin, injury and/or equipment damage  
 C - Optional – improves operating behavior, reliability and/or maintainability

|                                    |                                |
|------------------------------------|--------------------------------|
| <b>Chief Certification Officer</b> | <b>Chief Technical Officer</b> |
|                                    |                                |

**Reason and overview of the Service Bulletin (cause of problem if known)**

AutoGyro has received feedback from the market that in some circumstances in flight, particularly at altitude, the Rotax 915iS engine oil pressure can fall to its minimum operating pressure of 2 bar.

AutoGyro have developed an improved thermostat and oil cooler circuit that replaces the original assembly, improving oil flow and system pressure.

This service bulletin provides instructions on how to replace the oil thermostat and hose assembly.

**Manpower estimates**

The task may only be performed by an organization or individual entitled and trained to carry out maintenance on AutoGyro aircraft.

Estimated man-hours to complete the task as a stand-alone item is:

2.0 hrs including functional and leak checks.

**Compliance**

*There is no minimum embodiment requirement. However, the change improves oil flow and pressure, and therefore is considered to extend engine life.*

**Customer Support**

Materials and labour hours are covered by this Service Bulletin.

A maximum of 2 hrs labour may be claimed. Auto Gyro standard rate is 78.50€ per hour plus tax.

**The service bulletin reference AG-SB-2020-02-B-EN, gyro works number and engine serial number is to be quoted on all parts orders and labour claim submissions related to this SB.**

**Tooling required**

Standard tools.

**Weight and Balance Effects**

Nil

**Manuals affected**

POH & AMM AutoGyro is not affected.

**Previous Modifications that affect the SB**

None

**Accomplishment instructions (Action required to implement this bulletin):**

Effective date of this SB is 29 July 2020.

All work is to be carried out in accordance with the latest model-relevant AutoGyro Aircraft Maintenance Manual

**Instructions**

1. Ensure the wheel brakes are applied and the mag switches/ignition are switched in the "off" position.
2. Remove the upper and lower engine cowlings.
3. Measure the distance between the oil cooler corners as shown in Pic. 3 dimension 'X' to determine which hose set is required. If dimension 'X' is 280mm then oil hose set **47896** is required, if dimension 'X' is 335mm then oil hose set **47817** is required.
4. Confirm the size of the adaptor at the oil pump (Pic. 1 item A). If the thread size is anything other than 22mm then it must be replaced with adapter **45583**. If the thread is 22mm then no further action is required.
5. Confirm the size of the adapter at the oil cooler (Pic. 2). If the thread size is 18mm then adapter **45534** is required. If the thread is 22mm then no further action is required.
6. Return the oil in the system to the tank by turning the propeller until a gurgling sound is heard.
7. Place a container under the oil pump at the rear of the engine, and disconnect the oil hose (Pic. 1, item A). Allow any oil to drain and remove the P-clamp (Pic. 1, item B).
8. Disconnect the return hose from the right side oil cooler at the oil tank connection (Pic 2, item C)
9. Place a container under the oil cooler hose connections and disconnect the 4 hoses from the oil coolers (Pic 3. Items D, E, F & G). NOTE: Ensure to counter the adapters when dis-assembling and assembling the hoses on the coolers.  
Note: The thermostat and hoses are now supplied as separate items.
10. Assemble the new hoses (47896 or 47817) to the new thermostat (47748) loosely. Ensure that the items are assembled in the correct orientation as shown in Pic. 4.
11. Position the assembly between the oil coolers and connect the hoses to the 4 oil cooler connections, oil tank and oil pump.
12. Tighten all fittings using standard torques. Re-fit the P-clamp securing the oil pump hose.
13. Check the oil level in the tank and replenish if required.
14. Carry out an oil system purge in accordance with the Rotax 915 Line Maintenance Manual Chapter 12-20-00.
15. Re-check the oil level and replenish if required.
16. Carry out a loose tool and article check.
17. Carry out a ground run for a system leak check and thermostat functional check.
18. Check the oil level in the tank and replenish if required.
19. Refit the lower and upper engine cowlings.

**IMPORTANT:**

The Rotax 915iS is supplied with two possible sizes of oil tank and oil pump fittings depending on modification state. The earlier oil coolers on earlier versions of the Cavalon also have a varied position to the later versions. See 3, 4 and 5 above. **Ensure that the correct items are ordered for the mod state of the gyro as stated.**

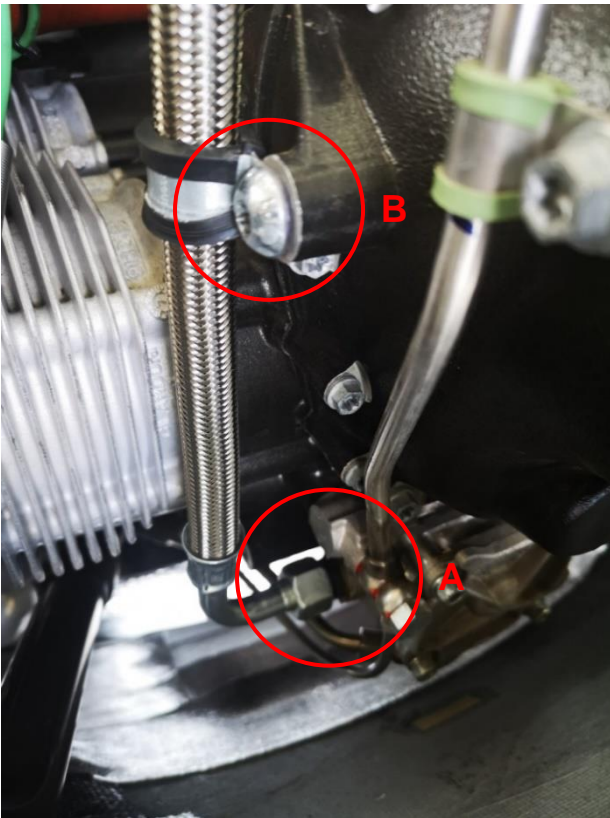
Illustrations

(Pic. 1)

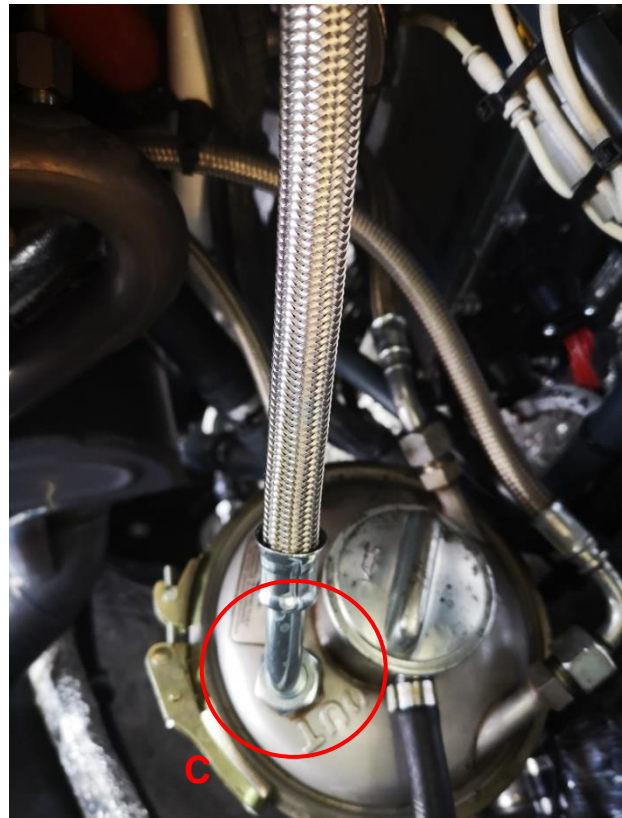

(Pic. 2)

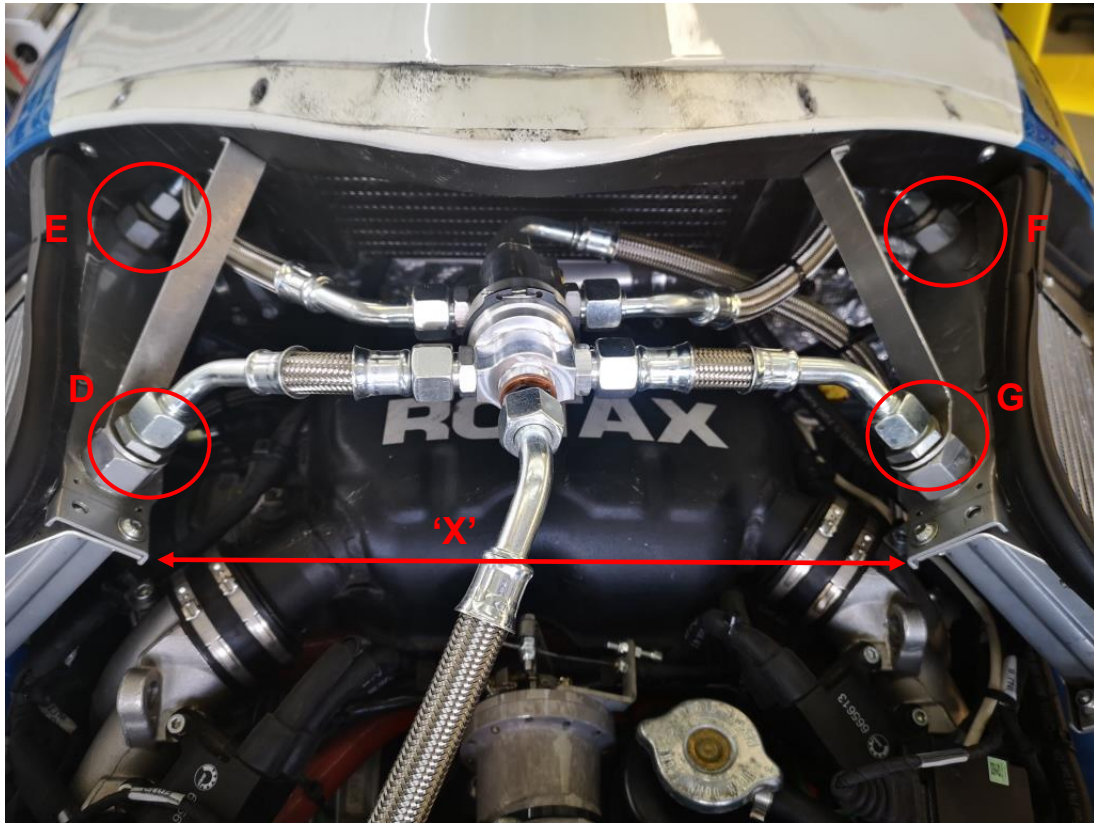

(Pic. 3)

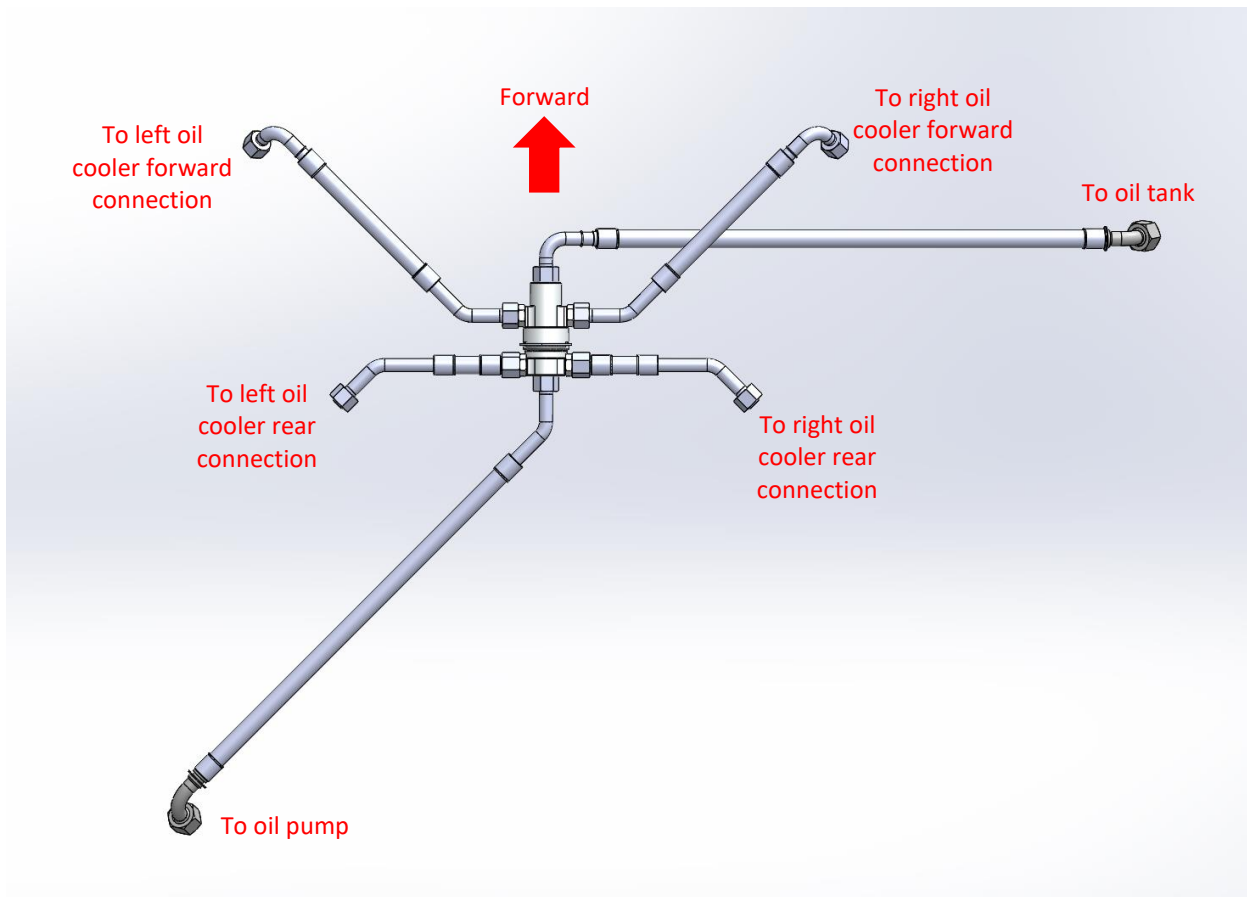

(Pic. 4)

**Completion of this Service Bulletin must be recorded within the aircraft documentation, in line with the requirements of the country of operation.**

**Material information (Parts required to be made to implement this service bulletin):**

Nil

**List of components (with purchasable part numbers)**

47748 Thermostat (all models)  
47896 Hose set (280mm dimension between oil coolers)  
47817 Hose set (335mm dimension between oil coolers)  
45583 Adaptor Oil Pump  
45534 Adaptor Oil Tank

**Interchangeability**

Not affected

**Parts disposition**

- a) Disposal requirements – Nil
- b) Environmental hazards of parts containing hazardous materials – Nil
- c) Scrap requirements (e.g. mutilate scrapped items beyond use) – Nil