

| | | |
|--|--|---|
| Title: Upgrade from Rotor System I to Rotor System II | | |
| AG-SB-2025-04-C-EN | Effective Date: 25.07.2025 | Compliance Category: A – MANDATORY B – RECOMMENDED C - OPTIONAL |
| Applicability | | |
| Aircraft type & model: AutoGyro MT-03 AutoGyro MTOsport (2010,"classic") Calidus | Affected Serial number(s): If fitted with Rotor System I | |
| The maintenance manual to be referenced is this stated or subsequent issue. | | As per AutoGyro website |
| <p>This form is the response from AutoGyro GmbH either against a problem found in the product in service requiring a containment or rectification action, or as service information for aircraft modification incorporation. For assistance, contact airworthiness@auto-gyro.com.</p> | | |

Documentation (Service Bulletin Completion action)

The accomplishment of this Service Bulletin, or the decision of its rejection, must be properly documented, if such procedure is required by the relevant authority.

Category Codes

- A – Mandatory – failure to comply result in a significant reduction of flight safety, injury or death
- B – Recommended – failure to comply may result in reduced safety margin, injury and/or equipment damage
- C - Optional – improves operating behavior, reliability and/or maintainability

Document approval signatures

| | |
|---|------------------------------|
| Head of Engineering | Head of Airworthiness |
| <p>The technical content of this document is approved under the authority of the UK CAA Design Organisation Approval Ref: DAI/9917/06</p> | |

Reason and overview of the Service Bulletin

AutoGyro developed a new Rotor System (Rotor System II) in 2011 offering significant improvements in service life.

A discounted upgrade package was offered some years ago to upgrade its fleet of gyrocopter Rotor Systems from System I to System II as the fleet started to near the life limit of the Rotor System I. This was predominantly carried out at the factory premises.

There are still a small number of Rotor System I assemblies in the market. This SB is to ensure how to upgrade from Rotor System I to Rotor System II.

This SB provides instructions for upgrading MT03, MTO Sport and Calidus aircraft currently fitted with a Rotor System I, to Rotor System II (standard, red end cap, or TOPP blue cap depending on the local Authority Aviation Approval).

Manpower estimates

The task may only be performed by an organization or individual entitled and trained to carry out the specified level of maintenance on AutoGyro aircraft.

Estimated man-hours to complete the task is:

Rotor System upgrade: 1.0 to 3.0 hours plus time required for Rotor balancing.

Compliance

This bulletin is recommended and has no compliance timeline. It must however be complied in the event of a Rotor System upgrade from Rotor System I to Rotor System II.

Customer Support

Materials and labour hours are not covered by this Service Bulletin.

Tooling required

Standard tools.
Rotor balance equipment if required

Weight and Balance Effects

Rotor System II (8,4m standard, red end cap) is 2,15kg heavier than the AutoGyro standard Rotor System I (8,4m, black end cap) and 2.90kg heavier than the AutoGyro 8,0 m Rotor System (grey end cap).

It is approximately the same weight as the very early Aircopter/Autogyro Systems.

Rotor System II (8.4m, TOPP, blue end cap) is 3,8kg heavier than the standard red end cap assembly.

Standard red end cap rotors are recommended for gyroplanes powered by the Rotax 912ULS engine.

If replacing a black or grey end cap System the greater weight on the top of the mast will raise the CG by approximately 7mm. This is within the current CG tolerance, due to the weight of the Rotor System II Rotor closely matching that of the original Aircopter Rotor fitted in 2006 when the MT-03 was first approved.

There is therefore no change in the certified max take-off weight or CG limitations of the aircraft.

The actual aircraft weight may however be changed so a new aircraft weight and balance certificate may be issued and the "Aircraft Payload Specification" placard amended. The data for the new certificate and placard change is listed below:

- If replacing black end cap 8,4m Rotor System add 2kg to the present declared weight
- If replacing a grey end cap 8,0m Rotor System add 3kg to the present declared weight
- If replacing an Aircraft 8,4m Rotor System do not amend the weight
- If replacing with a blue end cap rotor, add another 5,8kg to the present declared weight

Manuals affected

POH & AMM AutoGyro is not affected.

Previous Modifications that affect the Service Bulletin

None

Accomplishment instructions (Action required to implement this bulletin):

All work is to be carried out in accordance with the latest model-relevant AutoGyro Aircraft Maintenance Manual.

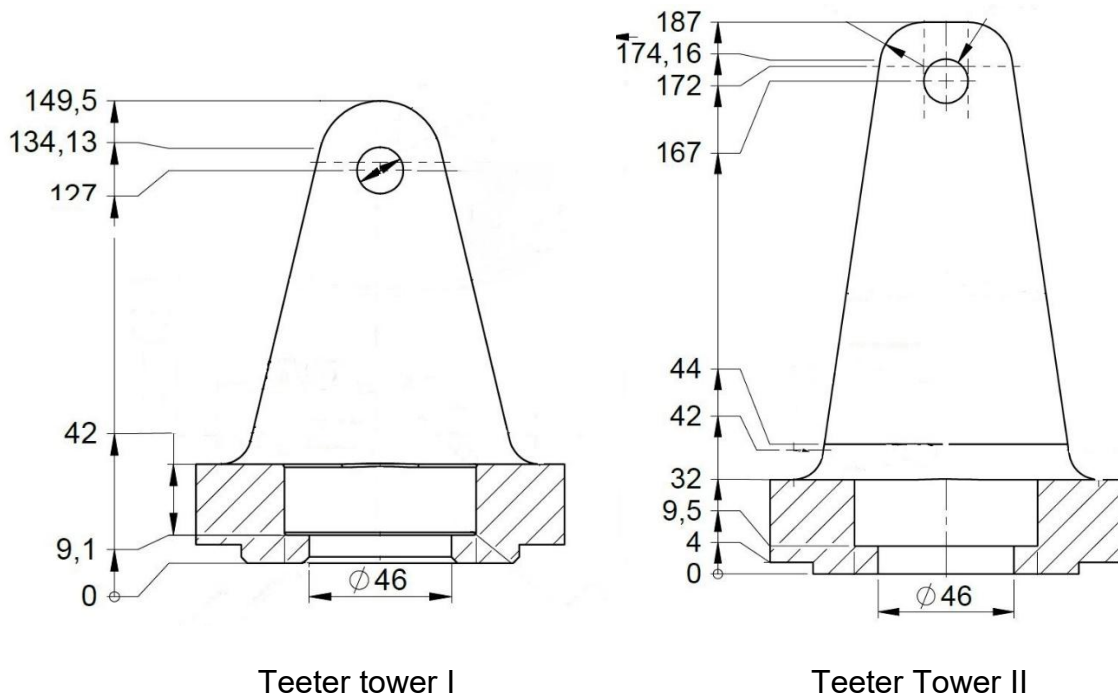

The newer Rotor System II 8,4m standard (red end caps, 8,4m TOPP (blue end caps) or 8,6m standard (grey end caps) is used with Teeter tower II.

An original Rotor System I (black end caps) must NEVER be fitted to a teeter tower II.

Instructions

MT03/MTOsport:

Rotor Head:

1. Remove the Rotor System in accordance with AMM job card 62-11-00 4-1.
2. Remove the teeter tower with crown gear assembly in accordance with AMM job card 62-20-00 8-1.
3. Replace the teeter tower I with the teeter tower II from the conversion set Rotor Head II (Part number 31895). It is strongly recommended that the aluminium spacer (b), main bolt (c) and nut (a) also be replaced. The spacer (d) is required for early versions of Calidus only.
4. It is also strongly recommended that the teeter bolt, washer and nut be replaced with the items from set (Part number 31895).
5. The temperature sensor (e) is included should the original item be damaged on disassembly. The sensor is assembled into the spacer using hot-glue. The sensor is orientated forward on assembly.
6. It is recommended also to replace spacers (f) so that Rotor balancing starts from a neutral point.

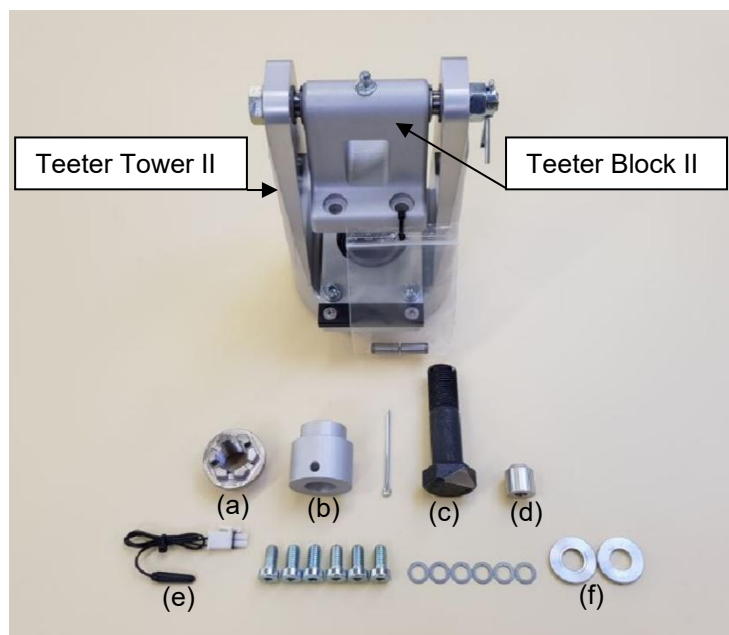

Conversion Set Rotor Head II 31895

7. Remove the gimbal from the lower Rotor Head assembly and confirm the version fitted. AMM job card 62-32-00 0-1 refers. Although a gimbal Head I is acceptable, it is highly recommended to replace with a gimbal Head II, part number 33615.
8. If required, replace the gimbal in accordance with AMM job card 62-32-00 8-1.

9. Re-assemble the teeter tower/main crown gear assembly in accordance with AMM job cards 62-20-00 8-1, 62-31-00 5-1 & 63-11-30 6-1.
10. Assemble the teeter block II delivered with the conversion set Rotor Head II 31895 to the new Rotor System (Rotor System article numbers are stated in the "List of Components" table below).
11. Assemble the new Rotor System and fit on the aircraft in accordance with AMM job card 62-11-00 4-4.
12. If the original rotor is to be retained in service, then the hours in service and hours remaining should be clearly marked on the rotor assembly by way of a suitable label.
13. Proceed to the section **Final Steps**.

Calidus:

1. Remove the Rotor System in accordance with AMM job card 62-11-00 4-1.
2. Remove the teeter tower with crown gear assembly in accordance with AMM job card 62-20-00 8-1.
3. Replace the teeter tower I with the teeter tower II from the conversion set Rotor Head II 31895. It is strongly recommended that the aluminium spacer (b), main bolt (c) and nut (a) also be replaced. The spacer (d) is required for early versions of Calidus only.
4. It is also strongly recommended that the teeter bolt, washer and nut be replaced with the items from set 31895.
5. The temperature sensor (e) is included should the original item be damaged on disassembly. The sensor is assembled into the spacer using hot-glue. The sensor is orientated forward on assembly.
6. It is recommended also to replace spacers (f) so that Rotor balancing starts from a neutral point.
7. Confirm that the correct gimbal is fitted to the Head. AMM job card 62-32-00 0-1 refers.
8. If required, replace the gimbal with version II (part number 33615) in accordance with AMM job card 62-32-00 8-1.
9. Re-assemble the teeter tower/main crown gear assembly in accordance with AMM job cards 62-20-00 8-1, 62-31-00 5-1, 62-32-00 5-1 & 63-11-30 6-1.
10. Assemble the teeter block II delivered with the conversion set Rotor Head II 31895 to the new Rotor System.
11. If a damper is fitted between the rear of the Rotor Head Bridge (at the pitch PPC connection) and the mast this must be removed and the spacer (d) inserted in its place on the pitch PPC assembly bolt.
12. Assemble the new Rotor System and fit on the aircraft in accordance with AMM job card 62-11-00 4-4.

13. If the original rotor is to be retained in service, then the hours in service and hours remaining should be clearly marked on the rotor assembly by way of a suitable label.

14. Proceed to the section **Final Steps**.

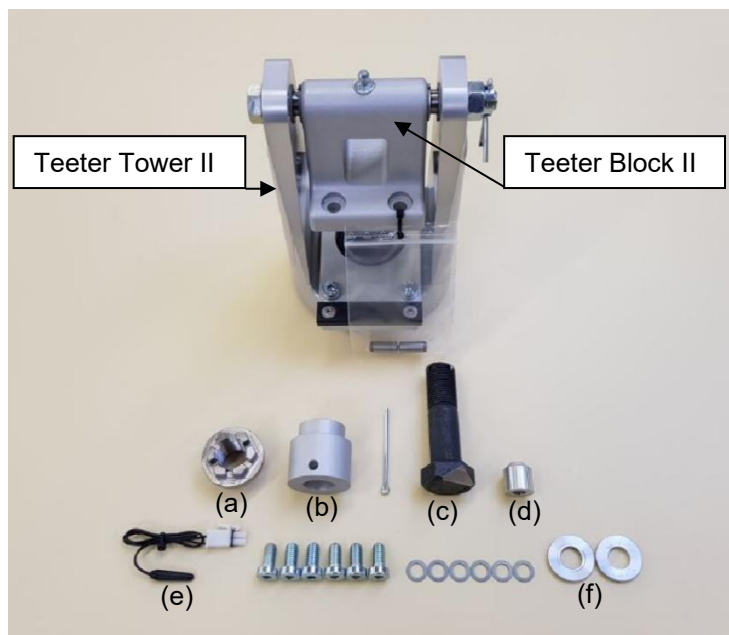

Conversion Set Rotor Head II 31895

Final Steps:

1. Carry out a FOD check of the aircraft.
2. Carry out a main Rotor control functional test for full and free range of movement.
3. Check that the rotor teeters to it's limit stops, and that the amount of teeter is equal in both direction, and around 12degrees total.
4. Carry out a flight test for Rotor balancing. It is strongly recommended that this is carried out by a suitably AutoGyro Certified mechanic certified as well for Rotor balancing.
5. Carry out a full flight test for correct function of the aircraft controls in flight.

Completion of this Service Bulletin must be recorded within the aircraft documentation, in line with the requirements of the country of operation.

Material information (Parts required to be made to implement this service bulletin):

Nil

List of components (with purchasable part numbers)

| MT03/MTO Sport | | | |
|-----------------------|-------------------------------|----------|---|
| Rotor System options | | | |
| Part Number | Description | Quantity | Remarks |
| 31793 | Rotor System II 8,4m | 1 | |
| 36228 | Rotor System II 8,4m OL | 1 | (subject to availability) |
| 33827 | Rotor System II 8,8m | 1 | Not approved in all countries |
| 37010 | Rotor System II 8,8m OL | 1 | Not approved in all countries (subject to availability) |
| GKS Rotor Head | | | |
| 31895 | Conversion set Rotor Head II | 1 | |
| 33615 | Conversion set Gimbal Head II | 1 | If required |
| Calidus | | | |
| Rotor System options | | | |
| Article | Description | Qty | Remarks |
| 31793 | Rotor System II 8,4m | 1 | |
| 36228 | Rotor System II 8,4m OL | 1 | (subject to availability) |
| 38946 | Rotor System II 8,4m TOPP | 1 | |
| 42423 | Rotor System II 8,4m TOPP OL | 1 | (subject to availability) |
| 45329 | Rotor System II 8,6m TOPP | 1 | |
| 45611 | Rotor System II 8,6m TOPP OL | 1 | (subject to availability) |
| 33827 | Rotor System II 8,8m | 1 | Not approved in all countries |
| 37010 | Rotor System II 8,8m OL | 1 | Not approved in all countries (subject to availability) |
| Rotor Head | | | |
| 31895 | Conversion set Rotor Head II | 1 | |
| 33615 | Conversion set gimbal Head II | 1 | If required |

Interchangeability

Not affected

Parts disposition

- a) Disposal requirements – Normal waste
- b) Environmental hazards of parts containing hazardous materials – Nil
- c) Scrap requirements (e.g. mutilate scrapped items beyond use) – Nil

Service Bulletin implementation Worksheet

| | | |
|-----------------------|-------------------|----------------------|
| Aircraft type: | Serial no: | Registration: |
|-----------------------|-------------------|----------------------|

| | |
|--------------------------------|----------------------|
| Worksheet completed by: | Document ref: |
|--------------------------------|----------------------|

| | |
|--|------------------------|
| Worksheet cross-checked by (if applicable): | AG-SB-2025-04-C |
|--|------------------------|

Purpose – record service bulletin implementation actions taken, to inspect the aircraft, and to return the aircraft to service.

| | |
|--|--|
| Maintenance manual referred-to and issue level: MMM-MT-A_16-02-08 2010 MMM-CD-A_16-02-08 | |
|--|--|

Note: attach SB sheets to this document

| Task | Notes | Eng'r check/date | Inspector check/date |
|---|---|------------------|----------------------|
| Remove the Rotor System | 62-11-00 4-1 | | |
| Remove the teeter tower | 62-20-00 8-1 | | |
| Replace the teeter tower with the new unit | 62-20-00 8-1 | | |
| Confirm the gimbal block version fitted and if changed | 62-32-00 0-1 | | |
| Re-assemble the rotorhead | | | |
| Assemble the teeter block II onto the rotor hub bar. | | | |
| Assemble the new Rotor System | 62-11-00 4-4 | | |
| Split pins installed correctly / disturbed fastening re-paint marked | Confirm number of pins changed | | |
| Rotor control functional test in pitch, roll and teeter axes | Confirm full travel to limit stops | | |
| Check and record teeter angle movement | | | |
| Flight test and Rotor balanced satisfactorily | | | |
| Entry of the work performed and release to service entry in the logbook | | | |
| Record of new rotor serial number and teeter tower serial number here and entered in the aircraft logbook | Rotor serial number: Teeter tower serial number: | | |

Customer acceptance:

| | |
|-----------------|-------------------------------|
| Name: | Aircraft hobbs meter reading: |
| Signature/date: | Confirm logbooks annotated: |

Permit Maintenance Release:
'The work recorded above has been completed to my satisfaction and in that respect the aircraft is considered fit for flight. I confirm that no tools, equipment or debris have been left in the aircraft'

| Service Bulletin implementation Worksheet | | |
|--|-------------------------------|------------------------|
| Aircraft type: | Serial no: | Registration: |
| Worksheet completed by: | | Document ref: |
| Worksheet cross-checked by (if applicable): | | AG-SB-2025-04-C |
| Engineer signature and date: | Location where work completed | |
| Authority Authorisation ref : | | |